



*Optimised for road and tunnel applications*

*Monitors obstruction to vision caused by fog, smoke and precipitation*

*Easily integrated with systems in road and tunnel applications*

## **KEY FEATURES & BENEFITS**

- 10m to 40km measurement range
- Compact forward scatter design
- Not affected by lights
- Easily installed by one person
- Hood heating for use in extreme environments
- Comprehensive self-test and maintenance data
- EXCO and MOR Outputs
- 3 Years warranty

The SWS-050T is designed for use in road and tunnel applications where accurate and reliable visibility measurements are required. The forward scatter measurement principle provides a compact design with measurements that are both accurate and reliable in all weather conditions. The SWS-050T outputs have been chosen to match those commonly used in tunnel systems.

### **Applications**

As road networks become more congested those tasked with the management of traffic flow and road user safety are turning to Road Weather Integration Systems (RWIS) to collect the meteorological data they need to keep the traffic moving. As conditions along a highway can change markedly over short distances due to the terrain and localised precipitation it can be necessary to deploy dense networks of reliable sensors so that a clear picture of the entire system is available. Such networks can however be costly to install and maintain unless the sensors are chosen carefully. The SWS-050T was specifically designed to meet the measurement accuracy and range requirements of RWIS users in a form which keeps acquisition and maintenance costs to a minimum. The sensor is simple and quick to install reducing lane closure requirements whilst design features such as window contamination monitoring with automatic measurement adjustment allow maintenance to be undertaken only when needed.

In remote locations, or where the terrain produces isolated danger areas, such as fog associated with low lying areas or rivers, the ability of the SWS-050T's relay outputs to control

local signage allows a simple and affordable warning system to be installed.

The safe operation of road tunnels present a unique challenge as whilst fog and certainly rain are unlikely the air quality can quickly deteriorate if the flow of air through the tunnel reduces



due to changes in the weather outside. Visibility sensors, especially those with an extended visibility range, can act as sensitive pollution monitors allowing the ventilation systems to be activated before pollution increases to dangerous levels. Visibility sensors can also form part of a fire detection system by detecting a sudden and isolated visibility decrease. The SWS-050T can be configured for a maximum measurement range of 40km making it a very sensitive sensor for both air quality and fire detection. To ease integration the sensor has the ability to report EXCO on a 4-20mA current output as favoured in tunnel systems, alternatively either the serial data output or optional relays can be used.

## Visibility Measurement

The measurement of visibility by forward scatter as used by the SWS-050T is now widely accepted and seen as having significant advantages over more traditional techniques such as the use of backscatter sensors or transmissometers. Backscatter sensors share the SWS-050T's advantage of being compact however the backscatter signal is strongly dependent on the type of obstruction to vision resulting in poor accuracy and limited upper range. More importantly due to the problem of reflections backscatter sensors require a large open area in front of the sensor to operate correctly. Transmissometer based sensors can produce accurate visibility measurements but the upper visibility limit is set by the sample path length which is always limited for reasons of practicality. The SWS-050T by contrast remains accurate to range of 40km and is not significantly influenced by objects around the sensor. To ensure the best possible results the calibration of the SWS sensor family was undertaken in accordance with the recommendations of International Civil Aviation Organisation and is traceable to a national weather service transmissometer.

## Interfacing, Connectivity and Cost of Ownership

The SWS sensor family is designed to be easily installed by a single person and has an interface which simplifies system integration. The ASCII text data message is transmitted at user defined time periods or in response to a polled request using a RS232, RS422 or RS485 interface. The standard data message provides both averaged Meteorological Optical Range (MOR) and atmospheric Extinction Coefficient (EXCO). For

applications where brightness information is required an optional interface to the ALS-2 Ambient Light Sensor is available. The ALS-2 Ambient Light Sensor data is appended to the standard sensor data message simplifying both installation and data processing.

To allow connection to analogue systems the visibility measurement is available as an analogue voltage or optionally as a 4-20mA current representing either MOR or EXCO. Three volt free contact change over relays offer user configurable outputs including visibility threshold, window contamination and sensor failure.

To keep track of the operational status of the sensor abbreviated self-test information is included in every data message with a full self-test report available on request. Self-test features include window contamination monitoring which automatically corrects the output data and provides two stage warnings allowing maintenance to be performed most efficiently. Calibration checks and recalibration are simple and quickly accomplished in the field by a single person. The need for such procedures is limited however as the stability of the light source and receiver circuitry is such that recalibration intervals are typically measured in years.

The SWS-050T is DC powered with the capability to accept separate supplies for sensor electronics and the high power hood heaters. Hood heating is only required in regions where blowing snow is encountered and to conserve power the heaters are only active when the temperature drops below 4°C.



## Sensor Configuration Information

For a detailed explanation of the configuration options please refer to the table below.

### 05T – SWS-050T Sensor

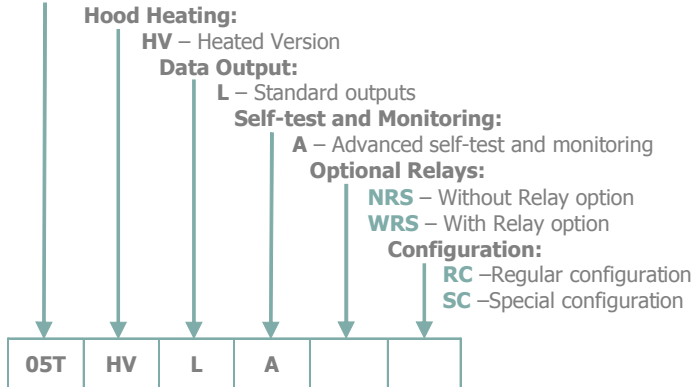

**Example:** **05T.HV.L.A.NRS.RC** (Please use this code when ordering your sensor).

## Configuration Options Explained

Option	Description
Hood Heating	Heated hoods are available to stop snow from accumulating around the optical windows. The sensor is fitted with hood heating as standard. No other option available. Option <b>HV</b> : Hood heating included
Data Output	The sensor has RS232, RS422 and RS485 serial output capabilities as standard. Both MOR and EXCO are available in the serial data output. Additionally there is a 0-10V analogue output and a 4-20mA signal representing either MOR or EXCO. No other options are available Option <b>L</b> : Standard outputs (RS232 and RS422/RS485 plus 0-10 Vdc & 4-20mA)
Self-Test & Monitoring	The sensor is provided with Advanced Self-Test capability. Advanced self-test capability provides monitoring of all the essential sensor functions, including contamination of the transmitter and receiver windows, plus receiver sensitivity monitoring. Advanced self-test capability provides greater measurement confidence in applications where different levels of contamination may occur on the sensor windows, for example where strong or gusty winds are experienced. No other options are available. Option <b>A</b> : Advanced Self-Test
Optional Relays	The sensor can be supplied with two threshold and one self-test relay. The threshold relays switch at a user defined visual range. Option <b>NRS</b> : Without relay option Option <b>WRS</b> : With relay option
Configuration	Reserved for customer specific configurations. Option <b>RC</b> : No customer specific configuration Option <b>SC</b> : Special customer specific configuration

# SWS-050T

## Visibility Sensor Specifications



### Visibility Measurement

Measures	Visibility (MOR) and Extinction Coefficient (EXCO)
Output	Serial Digital, 4-20mA and Voltage
Range (visibility) (Fixed, select at time of order)	MOR Default 10m-2km Selectable 10m to 10km, 10m to 20km, 10m to 32km or 10m to 40km EXCO 0.075-300km <sup>-1</sup>
Measurement Error	≤ 5% at 2km, ≤ 20% at 30km
Measurement principle	Forward scatter meter with 39° to 51° angle

### Outputs and Reports

Output rate (seconds)	10 to 300 (selectable)
Serial outputs	RS232, RS422 and RS485
Relay outputs	1 Fault and 2 Threshold Relays (option)

### Power Requirements

Sensor power	9-36 Vdc
Hood heating power	24 Vac or Vdc
Basic sensor	3.5 W
Window heaters	1.7 W
Hood heaters	24 W

### Additional Features

Hood heaters	Fitted as standard
Window contamination monitoring	Fitted as standard to both sensor head windows

### Environmental

Operating temperature	-40°C to +60°C
Operating humidity	0 – 100% RH
Protection rating	IP66/IP67

### Certification & Compliance

CE certified
EMC compliance with EN61326-1997, 1998, 2001
RoHS and WEEE compliant

### Physical

Material	Powder paint coated aluminium
Weight (incl. mounting kit)	4.3kg
Length	0.81m
Warranty	3 Years
Lifetime	>10 Years

### Maintenance

Self-test capability	As standard
User confidence check	6 months recommended
Window cleaning	Automatic compensation and warnings
Field calibration	With optional calibration kit

### Included with Sensor

The SWS sensor is delivered in sturdy recyclable foam filled packaging with:

- Pole mounting kit (2x U-bolt and saddles)
- User manual and calibration certificates

### Accessories – Optional

00.SWS.CABLE-D	SWS Series Data Cable per metre
00.SWS.CABLE-P	SWS Series Power Cable per metre
SWS.CAL	SWS Series Calibration Kit
SWS.CASE	SWS Series Transit Case
SWS.SK.100	SWS Series Spares Kit
SWS.WTY100	1 Year extended warranty
PW.MAINS	Mains Power Adaptor

Specifications are subject to review and change without notice. E&OE.

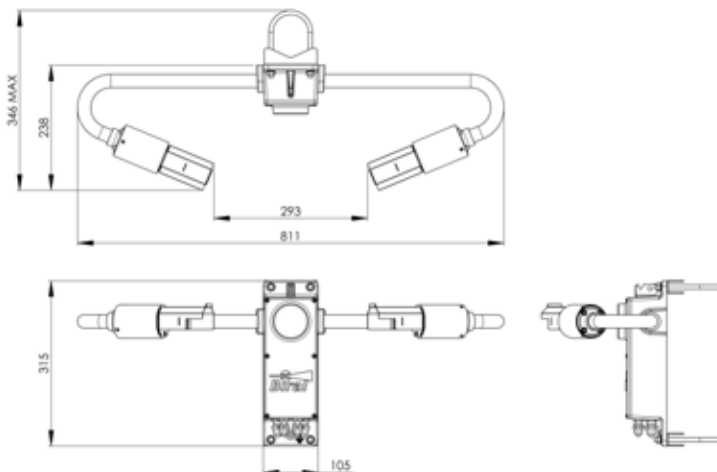

Dimensions in mm